

NOTES:

1. INPUT VOLTAGE: 28 VOLTS DC
 - CLOCK: 5mA MAX
 - 429 BUS: 300mA MAX
2. LIGHTING VOLTAGE: 28V, 150mA MAX
3. LIGHTING COLOR: BLUE WHITE
4. WEIGHT: .5 LB MAX
5. MATERIAL:
 - CASE: ALUMINUM ARINC 408A ATI2
 - BEZEL: FINISH IS LUSTERLESS BLACK IAW
 - FED-STD-595 NO. 37078
6. TIME IS MAINTAINED BY AN INTERNAL BATTERY WHEN EXTERNAL POWER IS REMOVED. ANTICIPATED BATTERY LIFE IS 10 YEARS.

REVISIONS			
REV	DESCRIPTION	DATE	APPROVED
-	INITIAL RELEASE #96661	10/29/00	

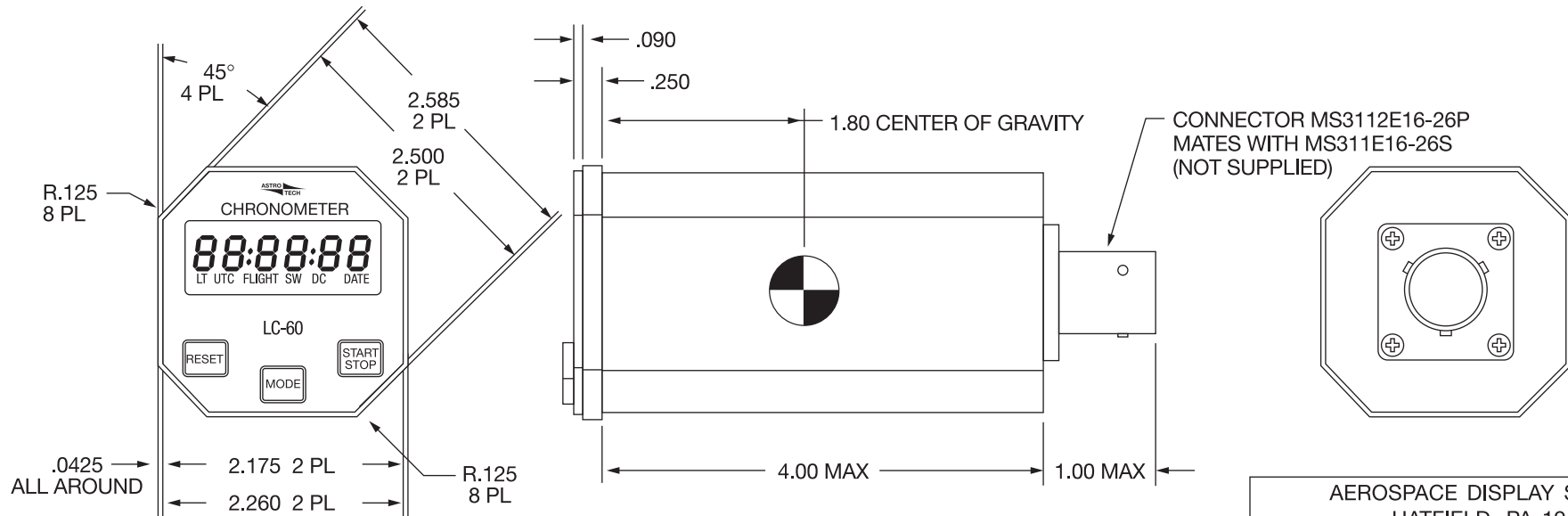

AEROSPACE DISPLAY SYSTEMS HATFIELD, PA 19440			
SIZE B	CAGE CODE 65907	DWG NO AT6421R1	REV —
SCALE 1/1	AT6421R1S02	SHEET 2 OF 3	

65907
DWG NO
AT660100
SHEET
REV C

REVISIONS			
REV	DESCRIPTION	DATE	APPROVED
-	INITIAL RELEASE #96661	11/29/00	

INSTALLATION WIRING DIAGRAM

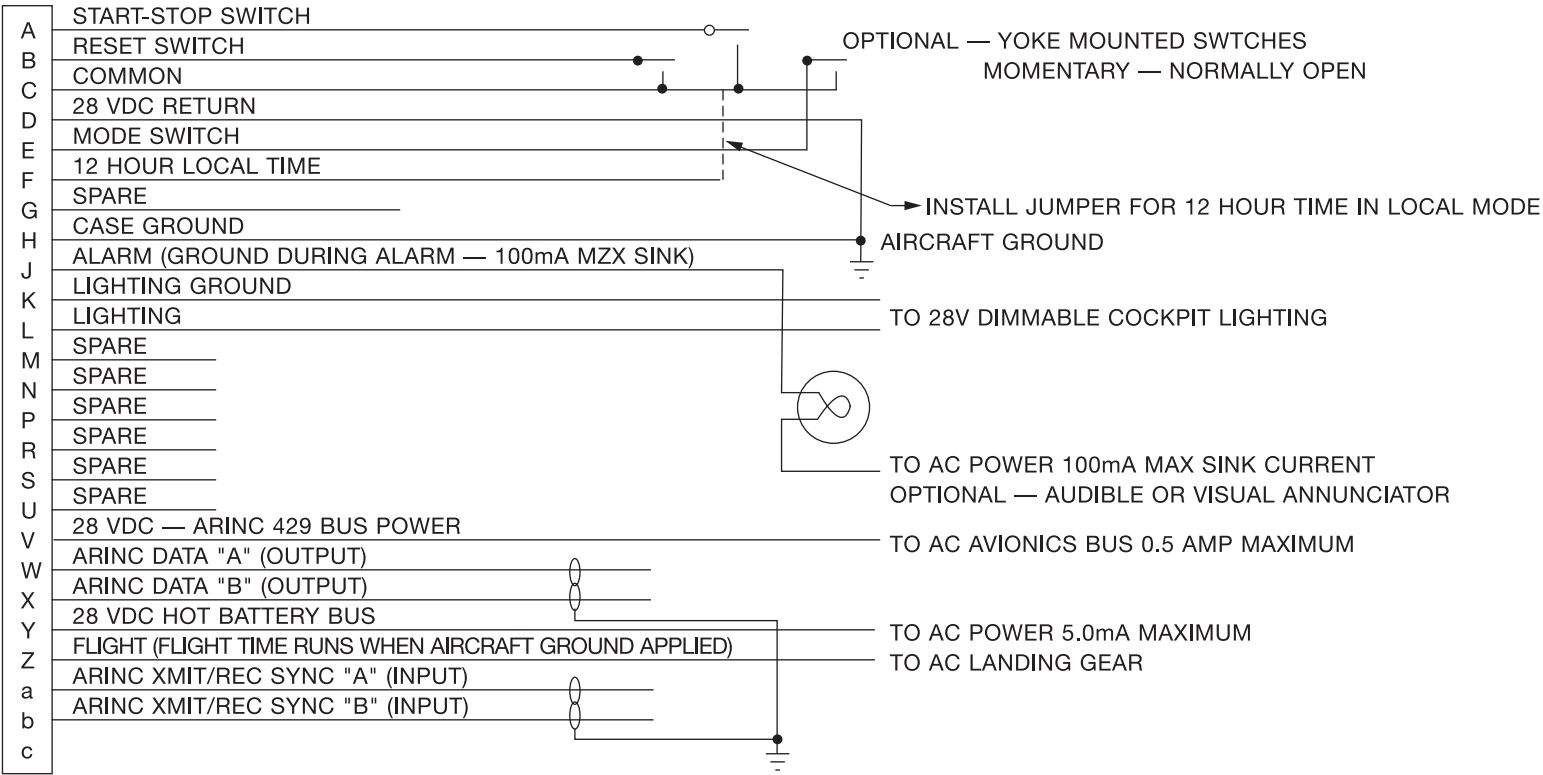

CONNECTOR — MS3112E-16-26P
 AC MATING CONNECTOR — MS3116E16-26S

65907
 DWG NO
 AT6421R1
 SH-3
 REV —

AEROSPACE DISPLAY SYSTEMS HATFIELD, PA 19440			
SIZE B	CAGE CODE 65907	DWG NO AT6421R1	REV —
SCALE NONE	AT6421R1S03	SHEET	3 OF 3