

# LC-90 SR Chronometer

by  
**Aerospace  
Display  
Systems**

The Aerospace Display Systems LC-90 SR is an ARINC 3ATI size chronometer designed for air transport service.

## Features:

---

- Liquid Crystal Display with dual numeric readout
- Sweep second hand
- ARINC 3ATI case
- ARINC 429 bus sends and receives date & time
- GPS compatibility with ARINC 429
- Date in DDMMYY format
- Elapsed time
- Chronograph
- Universal Coordinated Time (UTC)



# ADS

## Model LC-90 SR Chronometer

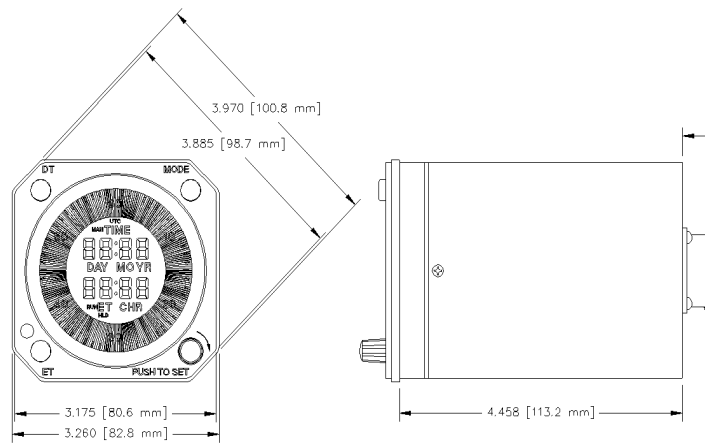

### LC-90 Design Basis

The ADS model LC-90 SR chronometer is designed for air transport use. It incorporates ARINC 429 communications for send and receive capability intercommunication such as a GPS receiver to other systems in the aircraft. The layout and design of the LC-90 make it an economical and reliable choice for OEM and retrofit installations with ease of maintenance. The solid state modular construction is resistant to dirt, vibration and the wear of mechanical clocks. A single user-friendly “push to set” knob easily sets the desired time or date.

### LC-90 Specifications

<b>CLOCK</b>	24 hour Universal Coordinated Time (UTC).
<b>DATE</b>	Date is displayed as DD/MM/YY and is year 2000 compliant.
<b>ELAPSE TIME</b>	Range is 00 to 59 minutes, 00 to 99 hours. Elapsed Time can be started - stop - restarted or reset.
<b>CHRONOGRAPH</b>	Range is 00 to 99 minutes, 00 to 59 seconds. Seconds are indicated by the sweep second pointer. An optional external chronograph switch can be used.
<b>DISPLAY</b>	Solid state Liquid Crystal Display (LCD) technology provides a continuous readout using negative image (white characters on black background) for excellent visibility during all operating conditions.
<b>LIGHTING</b>	The system provides high brightness white LED back-lighting during day operation and normal dimming control for night operation. Dimming is accomplished from the aircraft's 5V AC or DC, 400Hz lighting bus.
<b>POWER</b>	Power is supplied to the clock by the aircraft's +28 VDC Main bus and the +28 VDC Hot Battery bus. The +28 VDC Main bus draws a maximum current of 100mA and the +28 VDC Hot Battery bus draws 35mA of current.
<b>WEIGHT</b>	Less than 30 ounces (850 grams).
<b>INSTALLATION</b>	Installs into a standard 3ATI (3-inch air transport indicator) panel cutout using an ARINC 408A standard mounting clamp.
<b>ENVIRONMENTAL</b>	The LC-90 clock meets all of the applicable sections of RTCA DO-160.

<b>PART NO.</b>	<b>MODEL</b>	<b>DESCRIPTION</b>
AT945040	LC-90 SR	Panel mounted, aircraft powered, 5VAC or DC lighting